

### Micrometer Stands SERIES 156

#### Typical application



156-101-10

- Dedicated stand for micrometers.



156-101-10

- Designed to allow benchtop use of hand-held micrometers or other gages which have frames suitable for gripping by the clamp. Reduces the influence of temperature changes due to body heat, enabling higher-accuracy measurement.

#### SPECIFICATIONS

Code No.	Measuring range of standard outside micrometer	Remarks
156-101-10	15 - 100 mm (0.6 - 4 in)*	Adjustable angle type

\* Items that cannot be mounted on these stands (Code No. 406-253-30, 323-253-30, 331-254-30, 342-254-30, 342-264-30, 369-253-30, 422-232-30, 422-233-30, etc.)

#### DIMENSIONS

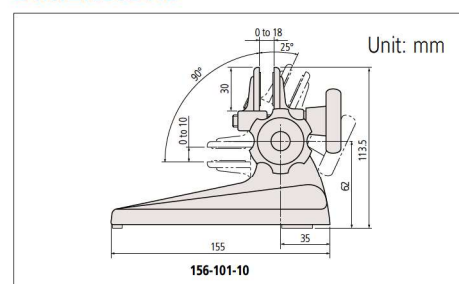

#### Typical application



156-105-10



156-105-10

#### SPECIFICATIONS

Code No.	Measuring range of standard outside micrometer	Remarks
156-105-10	25, 50 mm (1, 2 in)	Fixed angle type

#### DIMENSIONS

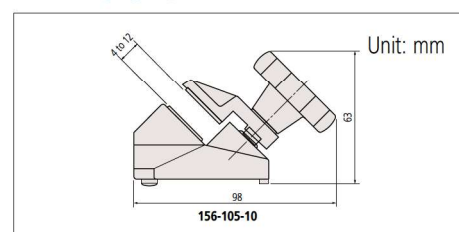

#### Typical application



156-102

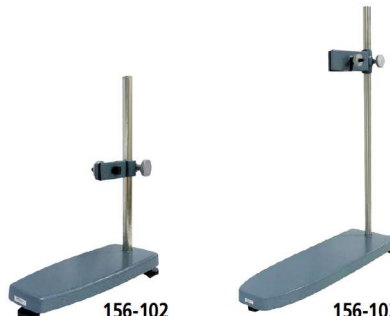

156-102

156-103

#### SPECIFICATIONS

Code No.	Measuring range of standard outside micrometer	Remarks
156-102	100 - 300 mm (4 - 12 in)	Vertical type
156-103	325 - 1000 mm (13 - 40 in)	Vertical type

#### DIMENSIONS

